

G9KB

PCB Power Relays

High Power Relay with Bidirectional Switching at 600 VDC, 50 A (Standard)/ 800 VDC, 100 A * (High-Capacity)



- * 100 A switching up to a maximum of 600 VDC
- Max. switching voltage 600 VDC (standard)/800 VDC (high-capacity)
- Rated carry/max. breaking current 50 A (standard)/100 A (high-capacity)
- Ambient temperature 85°C (Up to 105°C under specific conditions)
- Contact gap ≥3.6 mm
- Low initial contact resistance ≤5 mΩ
- The UL60947-4-1 and the EN61810-10 required for the energy storage system have been certificated

Refer to the *Precautions* on page 6.

Model Number Legend

G9KB-□□-□
1 2 3

- | | | |
|--------------------|-----------------|-------------------------------------|
| 1. Number of Poles | 2. Contact Form | 3. Special specification |
| 1: 1-pole | A: SPST-NO (1a) | None: Standard
E : High-capacity |

Application Examples

- Energy Storage System
- V2X (V2H, V2B, etc.)
- DC household appliances
- EV Charger

G
9
K
B

Ordering Information

Classification	Contact form	Enclosure rating	Model	Rated coil voltage (V)	Minimum packing unit
Standard	SPST-NO (1a)	Flux protection	G9KB-1A	12 VDC	36 pcs/box
High-capacity			G9KB-1A-E	24 VDC	

Note. When ordering, add the rated coil voltage to the model number.

Example: G9KB-1A DC12
└─ Rated coil voltage

Both the coil voltage on the product and the packing will be marked as □□VDC.

Ratings

● Coil

Rated voltage	Rated current (mA)	Coil resistance (Ω)	Must operate voltage (V)	Must release voltage (V)	Max. voltage (V)	Power consumption (mW)
			% of rated voltage			
12 VDC	Approx. 235.3	51	75% max. **	10 to 32%	110% (at 23°C)	Approx. 2,800 Approx. 575 *
24 VDC	Approx. 116.5	206				

Note 1. The rated current and resistance are measured at a coil temperature of 23°C with a tolerance of ±10%.

Note 2. The operating characteristics are measured at a coil temperature of 23°C.

Note 3. The maximum permissible voltage is the maximum value of the fluctuation range for the relay coil operating power supply and was measured at an ambient temperature of 23°C.

Note 4. Use this relay with coil voltage reduction.

* Power consumption with Holding Voltage is approx. 575 mW (when applying Holding Voltage at 45%). Please confirm the details on page 6, under ●Coil Voltage Reduction (Holding Voltage) during and after Relay Operation.

** Some mounting directions are not guaranteed. Please confirm the details on page 6 ●Mounting Direction.

● Contacts

Item	Standard	High-capacity
Contact type	Double break	
Contact material	Ag Alloy (Cd free)	
Rated load (Resistive load)	50 A at 600 VDC/1 A at 600 VDC/ 25 A at 500 VDC/10 A at 600 VDC/ 600 VDC making 1 A, carrying 35 A, breaking 1 A (at 85°C) 30 A at 600 VDC (at 105°C)	100 A at 600 VDC/100 A at 500 VDC/50 A at 800 VDC/ 18 A at 800 VDC (at 85°C) 50 A at 600 VDC/800 VDC making 1 A, carrying 50 A, breaking 1 A (at 105°C)
Rated carry current	50 A (at 85°C), 30 A (at 105°C)	100 A (at 85°C), 50 A (at 105°C)
Max. switching voltage	600 VDC	800 VDC
Max. switching current	50 A	100 A

Characteristics

Item	Classification	Standard	High-capacity
Contact resistance *1		5 mΩ max.	
Operate time *2		30 ms max.	
Release time *2		10 ms max.	
Insulation resistance *3		1,000 MΩ min.	
Dielectric strength	Between coil and contacts	5,000 VAC, 50/60 Hz for 1 min	
	Between contacts of the same polarity	2,500 VAC, 50/60 Hz for 1 min	
Impulse withstand voltage		Between coil and contacts 10 kV (1.2 × 50 μs)	
Vibration resistance	Destruction	10 to 55 to 10 Hz, 0.75 mm single amplitude (1.5 mm double amplitude)	
	Malfunction	Excitation: 10 to 55 to 10 Hz, 0.75 mm single amplitude (1.5 mm double amplitude) No excitation: 10 to 55 to 10 Hz, 0.15 mm single amplitude (0.3 mm double amplitude)	
Shock resistance	Destruction	1,000 m/s ²	
	Malfunction	Excitation: 100 m/s ² No excitation: 50 m/s ²	
Durability	Mechanical	1,000,000 operations min. (at 10,800 operations/h)	
	Electrical (Resistive) *4	(1) 600 VDC 50 A at 85°C 2,000 operations min. (2) 600 VDC 1 A at 85°C 100,000 operations min. (3) 500 VDC 25 A at 85°C 12,000 operations min. (4) 600 VDC 10 A at 85°C 50,000 operations min. (5) 600 VDC making 1 A, carrying 35 A, breaking 1 A at 85°C, 50,000 operations min. (6) 600 VDC 30 A at 105°C 2,000 operations min. (Switching frequency: 1 second ON - 9 seconds OFF 25% to 75% RH) *5	(1) 600 VDC 100 A at 85°C 100 operations min. (2) 500 VDC 100 A at 85°C 300 operations min. (3) 800 VDC 50 A at 85°C 10 operations min. (4) 800 VDC 18 A at 85°C 6,000 operations min. (5) 600 VDC 50 A at 105°C 3,000 operations min. (6) 800 VDC making 1 A, carrying 50 A, breaking 1 A at 105°C, 100,000 operations min. (Switching frequency: 1 second ON - 9 seconds OFF 25% to 75% RH) *5
Failure rate (P level) (Reference value) *6		1 A at 5 VDC	
Use conditions	Coil holding voltage *7	45% to 60% (at 85°C), 50 to 55% (at 105°C) of rated coil voltage	
	Ambient operating temperature	-40°C to 105°C (with no icing or condensation)	
	Ambient operating humidity	5% to 85%	
Weight		Approx. 110 g	

Note. The values given above are initial values at 23°C. (except electrical durability)

*1. Measurement conditions: 6 VDC, 20 A (after 30 seconds) voltage drop method.

*2. Measurement conditions: Applied rated coil voltage, no contact bouncing.

*3. Measurement conditions: Measured with a 1,000 VDC megohmmeter at the same point as the dielectric strength was measured.

*4. This specification is when diode and zener diode are used. For relay coil, please connect diode and zener diode.

For more detail, please refer to ●Diode Connection for Operating Coil on page 6.

*5. The humidity range of 25% to 75% conforms to the environmental conditions of JIS C 5442.

Also, refer to ●Relay Service Life on page 7.

*6. The value was measured at a switching frequency of 180 operations/ minute.

*7. For the detail regarding holding voltage usage, please refer to ●Coil Voltage Reduction (Holding Voltage) during and after Relay Operation on page 6.

Engineering Data

● Contact resistance

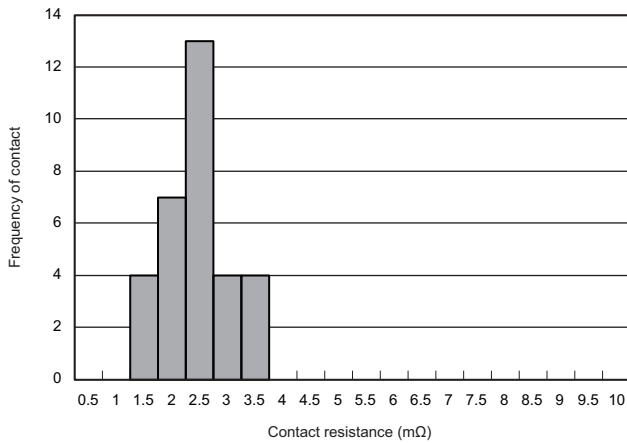

● Durability

G9KB-1A

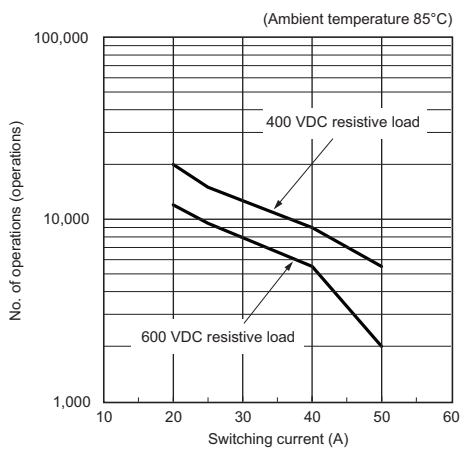

G9KB-1A-E

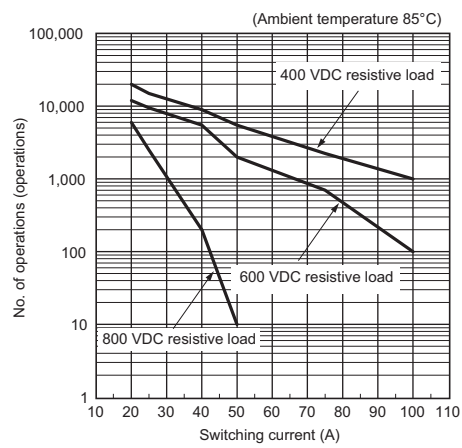

● Malfunction shock resistance

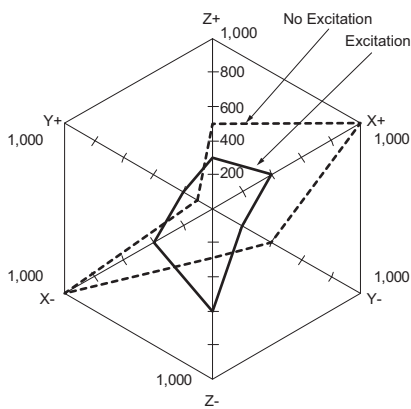

Measurement:

Measure the value of contact malfunction happening by applying 3 axes with 6 direction 3 times each. The energized voltage is within the range of the rated holding voltage.

Standard value:

Excitation 100 m/s²

No excitation 50 m/s²

Shock direction

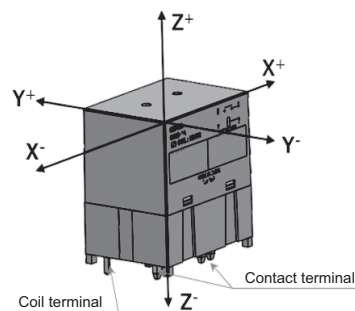

Dimensions

CAD Data marked products, 2D drawings and 3D CAD models are available.
For CAD information, please visit our website, which is noted on the last page.

(Unit:mm)

G9KB-1A, G9KB-1A-E

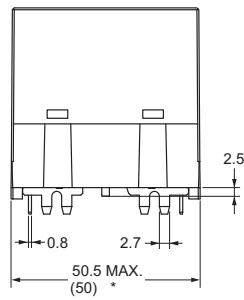
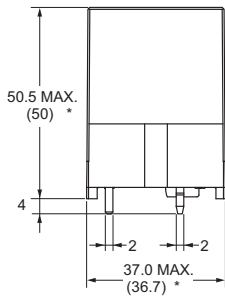

*Average value

Terminal Arrangement/
Internal Connections
(BOTTOM VIEW)

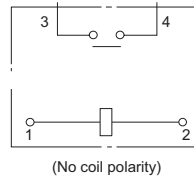

PCB Mounting Holes
(BOTTOM VIEW)

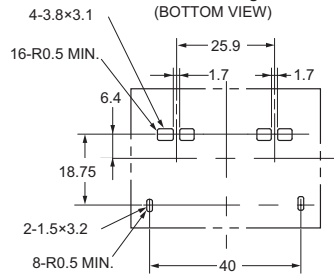

Tolerance ± 0.1

CAD Data

Approval Standard

UL/C-UL Certified:  (File No.E41515)

Model	Contact form	Coil ratings	Contact ratings	Number of test operations
G9KB-1A	SPST-NO(1a)	12, 24 VDC *	600 VDC 40 A (Resistive) 85°C	6,000
			600 VDC 50 A (Resistive) 85°C	2,000
			400 VDC 46 A (Resistive) 85°C	6,000
			500 VDC 25 A (Resistive) 85°C	12,000
			600 VDC 10 A (Resistive) 85°C	50,000
			600 VDC making 1 A, carrying 35 A, breaking 1 A, 85°C	50,000
G9KB-1A-E	SPST-NO(1a)	12, 24 VDC *	600 VDC 100 A (Resistive) 85°C	100
			500 VDC 100 A (Resistive) 85°C	300
			800 VDC 50 A (Resistive) 85°C	10
			800 VDC 18 A (Resistive) 85°C	6,000
			830 VDC 20 A (Resistive) 85°C	2,500

* Holding voltage of 45% (after applying rated voltage to coil for 0.1 seconds)

EN/IEC, TÜV Certified:  (Certificate No.R 50528195)

Model	Contact form	Coil ratings	Contact ratings	Number of test operations
G9KB-1A	SPST-NO(1a)	12, 24 VDC *	600 VDC 1 A (Resistive) 85°C	100,000
			600 VDC 50 A (Resistive) 85°C	2,000
G9KB-1A-E	SPST-NO(1a)	12, 24 VDC *	600 VDC 100 A (Resistive) 85°C	100
			500 VDC 100 A (Resistive) 85°C	300
			800 VDC 50 A (Resistive) 85°C	10
			800 VDC 18 A (Resistive) 85°C	6,000
			830 VDC 20 A (Resistive) 85°C	2,500

* Holding voltage of 45% (after applying rated voltage to coil for 0.1 seconds)

CQC Certified:  (Certificate No.CQC21002322255)

Model	Contact form	Coil ratings	Contact ratings	Number of test operations
G9KB-1A	SPST-NO(1a)	12, 24 VDC *	600 VDC 1 A (Resistive) 85°C	100,000
			600 VDC 50 A (Resistive) 85°C	2,000
G9KB-1A-E	SPST-NO(1a)	12, 24 VDC *	600 VDC 100 A (Resistive) 85°C	100
			500 VDC 100 A (Resistive) 85°C	300
			800 VDC 50 A (Resistive) 85°C	10
			800 VDC 18 A (Resistive) 85°C	6,000
			830 VDC 20 A (Resistive) 85°C	2,500

* Holding voltage of 45% (after applying rated voltage to coil for 0.1 seconds)

Insulation data	Classification	G9KB-1A		G9KB-1A-E
Creepage distance -between coil and contact		12.6 mm min.		12.5 mm min.
Clearance -between coil and contact		8 mm min.		8 mm min.
Type of insulation -between coil and contact		Basic insulation	Reinforced insulation	Basic insulation
Type of interruption		Micro disconnection		
Conditions of insulation data				
Material group of insulation		IIIa		
Pollution degree (external environment of the relay)		3	2	3
Rated insulation voltage		600V		800V
Overvoltage category	Altitude up to 2,000 m	III		
Other data				
Category of protection (IEC61810-1)		RTII		
Flammability class (UL94)		V-0		
Coil insulation system (UL 1446)		Class F		

Precautions

- Please refer to “Safety Precautions for All Relays” for correct use.
- **Electrical Appliances and Materials Safety Act**

The G9KB series does not comply with the Electrical Appliances and Materials Safety Act. Please select our relays carefully in accordance with the application you wish to use the product for.

Warning

As this relay is a high-voltage and high-current type, there is a risk of abnormal heat generation, smoke generation or fire if you use the relay with a contact voltage, current, or for a number of times beyond the specified range. Use only within the specified ranges.



If the power is switched on when the connections are insufficient, there is a risk of abnormal heat generation. Do not connect and use probes and sockets on individual relays.



If the power is switched on when the connections are insufficient, there is a risk of abnormal heat generation. Please install and use relays under recommended conditions.



Precautions for Safe Use

- **Drop**
 - Do not use relays that have been dropped as they may not function properly.

Precautions for Correct Use

- **Mounting Direction**
 - The relay is limited for mounting direction due to the specification of operation voltage and electrical durability. Do not use in any other direction except as indicated in below chart. There is a risk of reduced operational lifetime for failure to observe this warning.

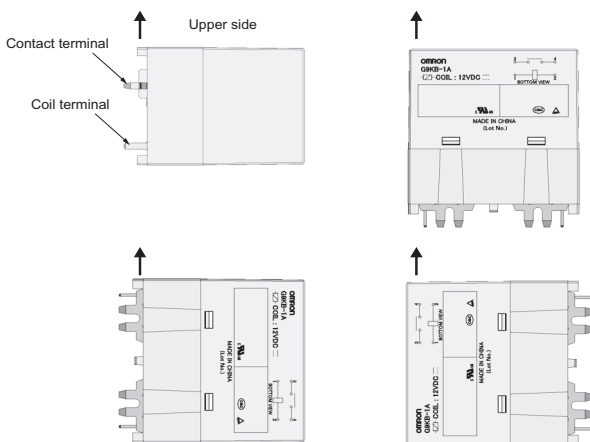

● Coil Voltage Reduction (Holding Voltage) during and after Relay Operation

- Use this relay with coil voltage reduction.
- Use the relay in the applied voltage and time ranges indicated in the figure and table below.
- Configure the settings so as not to exceed these ranges due to the change of coil voltage difference.

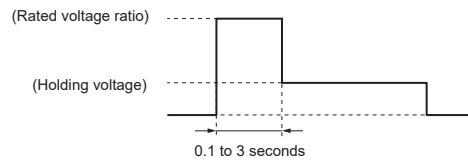

	Ambient temperature 85°C max.	Ambient temperature 85 to 105°C
Rated voltage ratio	100 to 110%	135 to 150%
Holding voltage	45 to 60%	50 to 55%

● Diode Connection for Operating Coil

- Connect diode and Zener diode (or Varistor) to the coil (refer to the picture below). Diode is for coil surge absorption. Ensure to include Zener diode as there is a possibility of any influence for switching capability when only using diodes.
- Coil has no polarity. Connect the diodes in the reverse polarity of the voltage applied to the coil.
- The recommended Zener diode voltage is 3 times that of the rated coil voltage.
- Use diodes with reverse dielectric strength 10 times or more that of coil rated voltage, and with forward current more than coil rated current.

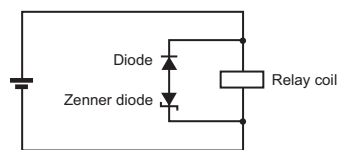

● PCB Terminal soldering

- Solder at 290°C for 20 seconds (max.) in soldering bath.
- It is not possible to wash relay as this is not fully sealed type.

● Assembly

- Assemble relays in an environment with less amount of dust and harmful gases.
- Using the Relay under high temperature, high humidity, or harmful gas may deteriorate its performance characteristics due to condensation or corrosive materials, resulting in failure or burn damage to the relay.
- This product weight is about 110 g. Be careful of the strength of PCB. To reduce soldering crack due to heat stress, use both sides through hole PCB.

● Relay Service Life

- These relays must be used for high DC voltages. The final failure mode is failure to break the circuit. In a worst-case scenario, burning may extend to surrounding components. Do not use these relays outside of the specified ratings and service life, or for any application other than high DC voltages. Implement safety circuits and other safety measures to minimize the risk in case of the unlikely event of a failure.
- In a low-humidity or low-temperature (negative) environment, the life cycle may vary as a result of high voltage and large-current opening and closing. Therefore, be sure to check on the actual machine.
- The coil drive circuit, ambient environment, switching frequency, or load conditions (e.g., inductive load or capacitor load) may reduce the service life and possibly lead to failure to break. Always confirm the service life in the actual equipment.

● Micro load

- This is a power relay for high power switching. Do not use for micro loads such as signal switching.

● Mounting interval

- A mounting interval of 20 mm (G9KB)/50 mm (G9KB-E) minimum is recommended for this relay. This is based on OMRON's evaluation results and serves as a guideline for ensuring stable product operation. In environments where sufficient cooling is ensured (e.g., by fans), more flexible placement may be possible. Additionally, mutual magnetic interference may cause changes in the relay's characteristics. In actual design, be sure to verify performance using the actual equipment before use.

● The Effects of Magnetic Fields from Permanent Magnets

- This product contains permanent magnets, which may generate magnetic fields that can interfere with nearby electronic components or sensors. When designing, pay close attention to the distance and placement relative to magnetically sensitive components (e.g., current sensors, magnetic sensors etc.).
Due to the effects of magnetic fields varying depending on the operating environment and characteristics of surrounding components, ensure to perform thorough evaluations beforehand.

Please check each region's Terms & Conditions by region website.

OMRON Corporation

Device & Module Solutions Company

Regional Contact

Americas

<https://components.omron.com/us>

Asia-Pacific

<https://components.omron.com/ap>

Korea

<https://components.omron.com/kr>

Europe

<https://components.omron.com/eu>

China

<https://components.omron.com.cn>

Japan

<https://components.omron.com/jp>