

Rated 500 VDC, 10 A (2-pole series connection) G2RG-X, a compact PCB power relay with DC high voltage switching

Contribution of OMRON's high-capacity relays in solving social issues

In recent years, energy-related equipment such as solar power generation systems, energy storage, and electric vehicles (EVs) have been introduced in large numbers to areas where there is a demand, and the conventional infrastructure of large-scale centralized power supplies is being transformed to coexist with small-scale distributed power supplies. These distributed power supplies are becoming essential for decarbonization and energy security. While maximizing energy efficiency, their safety and reliability as energy infrastructure must also be ensured.

By expanding its product lineup of high-capacity relays that are implemented in the distributed power supplies, OMRON will ensure product quality so that customers can use these relays safely and securely. OMRON will also contribute to solving social issues by improving usability and energy efficiency through reductions in size and weight as well as contact resistance.

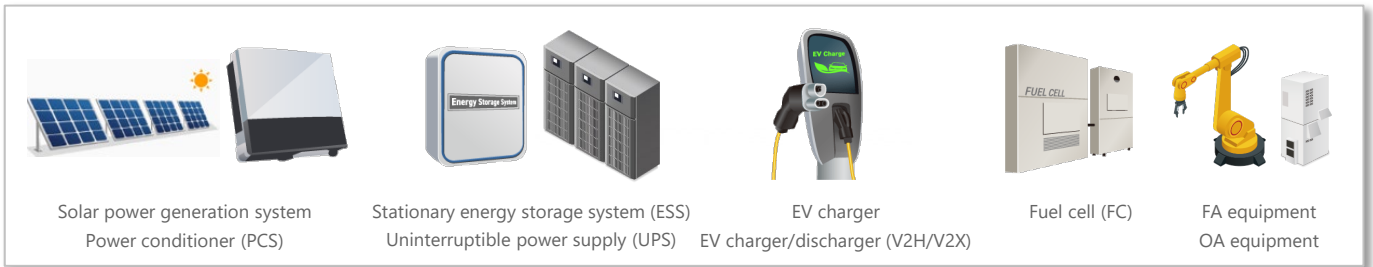

[Fig. 1: Application examples where OMRON's high-capacity relays are focused]

Rated 500 VDC, 10 A (2-pole series connection) G2RG-X, a compact PCB power relay with DC high voltage switching

Value provided by G2RG-X

G2RG-X is a PCB relay rated 500 VDC, 10 A with 2-pole series wiring. This product is ideal for opening and closing rectifier circuits for 200 VAC systems where 300 to 400 VDC is used, and inrush current prevention circuits for DC power supply systems, household storage batteries. The 2-pole relay series connection allows for the miniaturization of equipment.

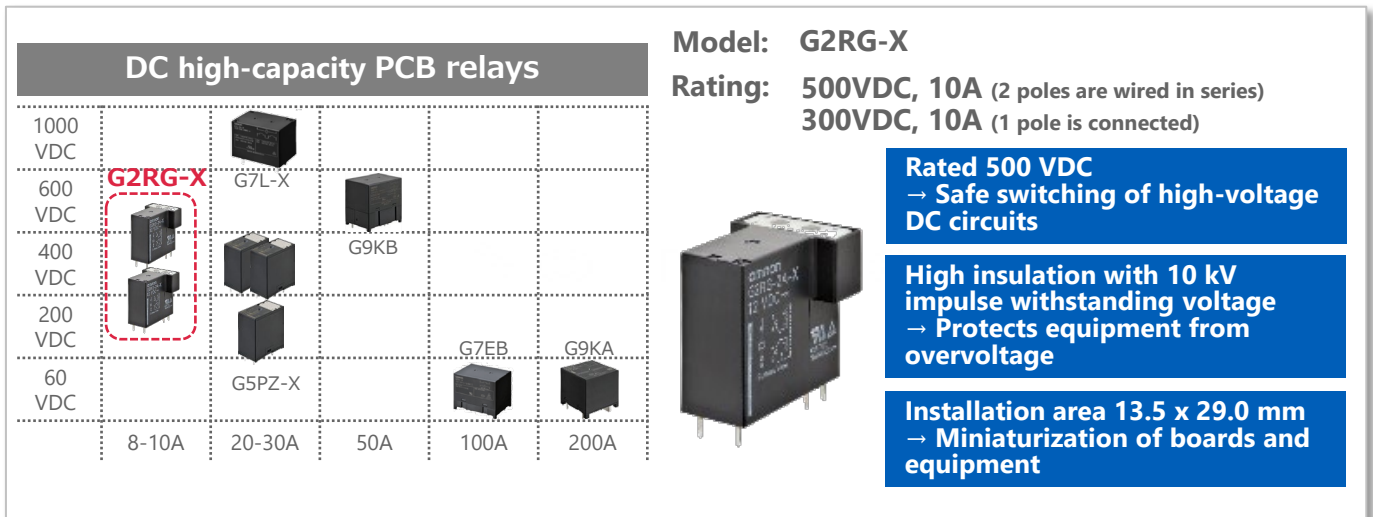

[Fig. 2: DC high-capacity relay lineup and G2RG-X features and offered value]

Rated 500 VDC, 10 A (2-pole series connection) G2RG-X, a compact PCB power relay with DC high voltage switching

Market trend: Expanding use of DC distributed power supplies and DC power supplies

In recent years, as efforts to solve environmental issues such as the SDGs and decarbonization have become increasingly important, solar power generation has been installed in homes and businesses. On the other hand, such natural energy power generation is an uncontrolled power supply whose output is dependent on weather conditions. In addition, a separate regulating power supply is needed to match the supply and demand of electricity. As one means of achieving this, storage batteries are increasingly being installed alongside solar power generation. Generally, AC electricity is used for power distribution. Both solar generation system and storage batteries are DC power supplies, but technology is being developed to increase energy efficiency and reliability by directly connecting them in a DC circuit instead of through an AC distribution line. But DC is more difficult to interrupt than AC, and energy-related equipment, especially those that carry relatively large currents, require a means to quickly and reliably interrupt the current in an emergency. OMRON is developing DC power relay products to help solve such social issues. Through the development of technology to efficiently interrupt the arc discharge that occurs when a DC current is interrupted, this product is smaller and lighter than conventional electromagnetic contactors and can be mounted on PCBs, contributing to the spread and expansion of energy-related equipment that is compact and can be mass-produced.

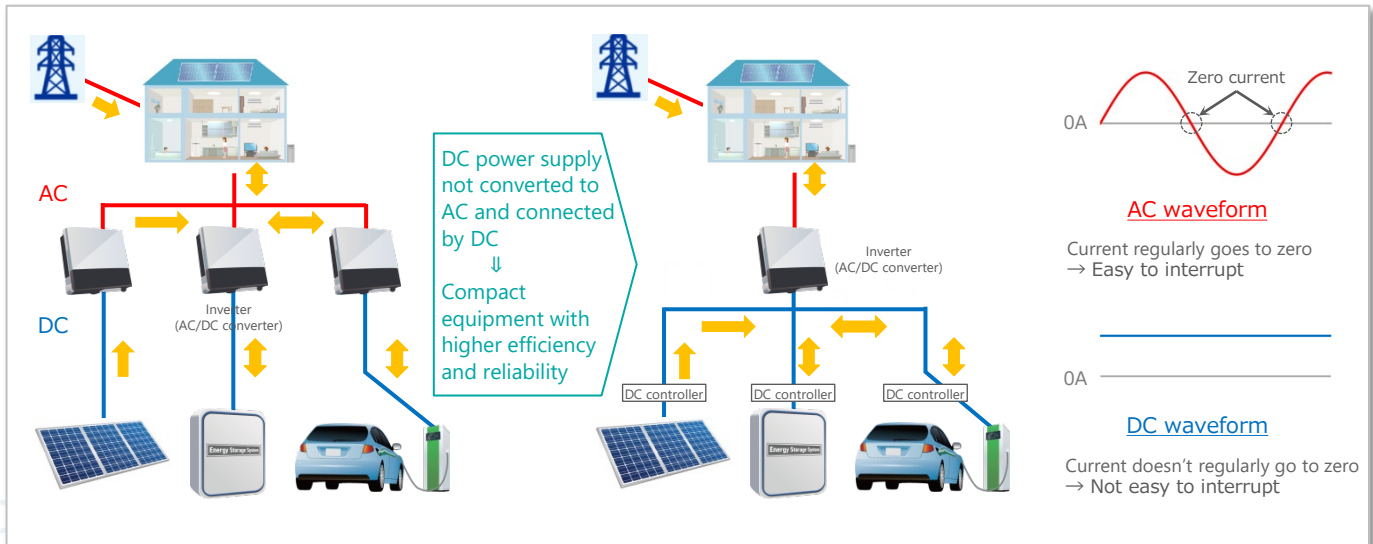

[Fig. 3: AC and DC interconnections of various DC distributed power supplies (DC link)]

Rated 500 VDC, 10 A (2-pole series connection) G2RG-X, a compact PCB power relay with DC high voltage switching

In data centers and telecommunication buildings, where high reliability is required, uninterruptible power supplies (UPS) are installed to prepare for power outages. The development of DC power supply technology is underway to directly connect the storage batteries in the UPS, which are DC power supplies, to servers that operate on DC, without passing through AC power distribution lines. In 2012, the International Telecommunication Union (ITU), an International Organization in the telecommunications field, approved ITU-T Recommendation L.1200 (Interface Specifications for DC Power Feed Systems) in 2012 and defined a DC power supply interface for ICT equipment with a minimum voltage of 260 VDC and a maximum voltage of 400 VDC.

The G2RG-X achieves a rated load of 500 VDC, 10 A through a 2-pole series connection, and is suitable for the DC voltage range required for stationary energy storage systems (ESS) annexed to solar power generation facilities and DC power supply systems in data centers and other facilities.

App example: Switching inrush current protection circuit and discharge circuit (ESS, UPS, etc.)

The G2RG-X can also be used in inrush current protection circuits (precharge circuits) to limit the excessive charging current to the internal capacitor when the equipment starts up, and in discharge circuits to discharge the internal capacitor to a safe voltage when the equipment stops.

An inrush current protection circuit and a discharge circuit are generally attached to the DC circuit of ESS or UPS. These circuits disconnect the storage battery when the equipment is shut down and discharge the capacitor using the discharge circuit to lower the voltage to a safe level.

On the other hand, when the equipment starts up, the storage batteries are connected via the inrush current protection circuit, and the capacitors are charged from the storage batteries. Then, when the voltage of the capacitors becomes almost equal to the voltage of the storage batteries, the switchgear of the main path of the DC circuit is closed and the switchgear of the inrush current protection circuit is opened to put the equipment into operation.

Rated 500 VDC, 10 A (2-pole series connection) G2RG-X, a compact PCB power relay with DC high voltage switching

A voltage equivalent to that of the storage battery is applied between the terminals of the switch when the circuit is open. As with the before mentioned switching applications for DC power circuits, the need for the switch that can handle high voltages has increased in recent years.

Generally, inrush current protection and discharge circuits consist of relays and other switches and resistors that limit the charging and discharging currents, and they are connected in series or parallel with the capacitor, respectively. The larger the capacitance of the capacitor and the larger the resistance value of the limiting resistor, the longer the time required for charging or discharging, so select an appropriate resistance value according to the design target time. The peak value of the charging current or discharging current is determined by the resistance value and the power supply voltage (voltage of the storage battery), so select a switch capable of turning on and off that current.

In general, the current flowing through inrush current protection circuits and discharge circuits is often smaller than the current in the main circuit, so the G2RG-X may be applicable to inrush current protection and discharge circuits in ESS and UPS with outputs exceeding 10 kW. However, the design of inrush current protection circuits and discharge circuits is affected by factors other than the output capacity of the equipment, so please determine applicability after conducting detailed design and testing.

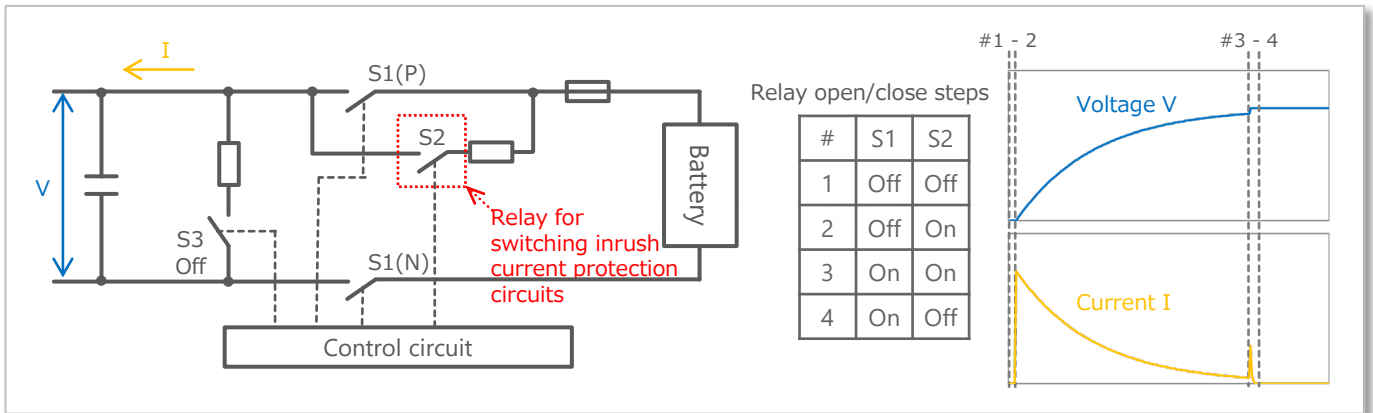

[Fig. 4: Application example for inrush current protection circuit (precharge circuit) in ESS]

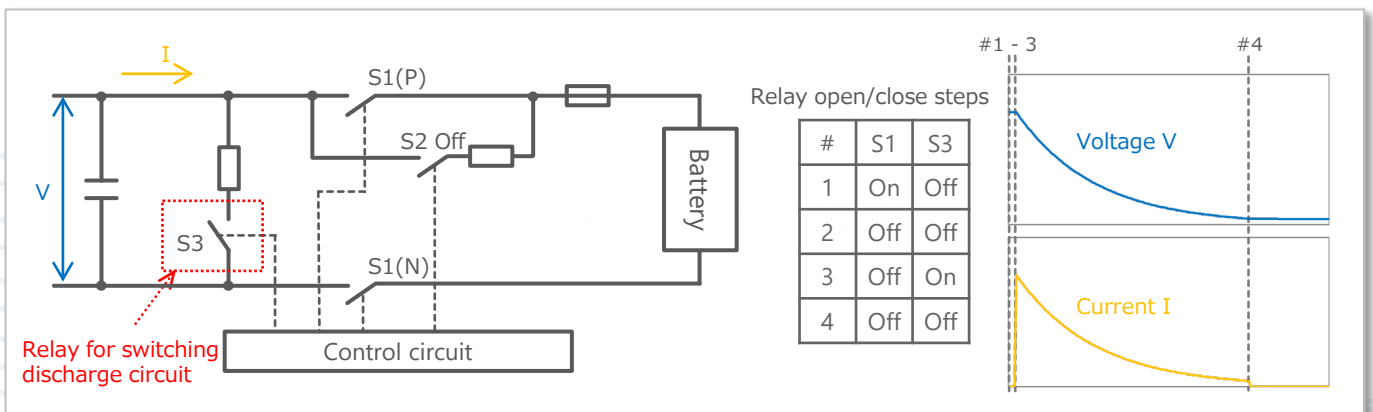

[Fig. 5: Application example for discharge circuits in ESS]

Rated 500 VDC, 10 A (2-pole series connection) G2RG-X, a compact PCB power relay with DC high voltage switching

Product feature: DC high voltage switching

The G2RG-X is designed to extend the arc with a permanent magnet mounted near the contact point to achieve stable circuit interruption in DC high voltage switching of 500 VDC, 10 A. Due to its high insulation performance, G2RG-X can be used safely for DC devices. With energy-saving power consumption of 0.8 W, it can be used for DC switching applications, which have been increasing in recent years in response to the demand for EVs and renewable energies. In addition, high voltage may be applied to various electrical equipment but the G2RG-X does not cause dielectric breakdown even at 10 kV.

	Electrical durability
1-pole series wiring	10,000 operations at 300 VDC 10 A (switching frequency 1 sec ON-9 sec OFF at 85 °C)
2-poles series wiring	10,000 operations at 500 VDC 10 A 30,000 operations at 500 VDC 1 A (switching frequency 1 sec ON-9 sec OFF at 85 °C)

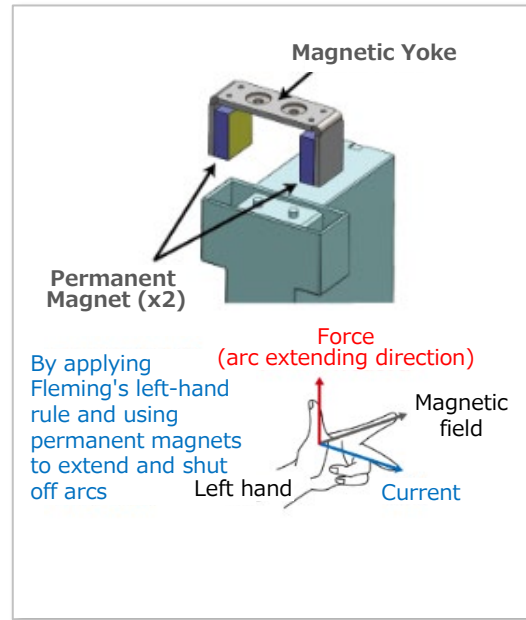

[Fig. 6: Arc interruption by permanent magnet]

*This is the case when a diode and a Zener diode are used. The relay coil should be connected to the diode and the Zener diode.

Product feature: Compact size

The compact body and small footprint (29mm×13.5mm) of G2RG-X contributes to the miniaturization of printed circuit boards.

Its mounting floor space is almost the same as that of the G2R, yet it achieves high voltage switching of 500 VDC, 10 A.

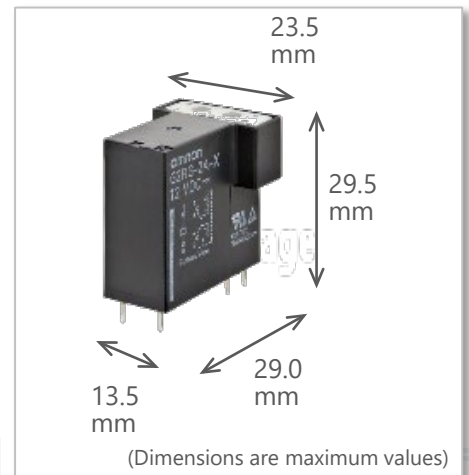

[Fig. 7: G2RG-X sizes]

Rated 500 VDC, 10 A (2-pole series connection) G2RG-X, a compact PCB power relay with DC high voltage switching

Product specifications

For the latest product information, please refer to the datasheet on our website.

23.5 mm
29.5 mm
13.5 mm
29.0 mm
(Dimensions are maximum values)

Item		2-pole series connection	1-pole connection
Coil	Coil voltage	12 VDC, 24 VDC	12 VDC, 24 VDC
	Power consumption	approx. 800 mW	approx. 800 mW
Contact	Contact form	2a(2 poles series wiring)	2a(1 pole series wiring)
	Rated load (Resistive load)	500 VDC 10 A	300 VDC 10 A
	Rated carry current	8 A (85°C), 10 A (65°C)	8 A (85°C), 10 A (65°C)
	Max. switching voltage	500 VDC	300 VDC
	Max. switching current	10 A	10 A
Durability	Mechanical	1,000,000 times or more (switching frequency 18,000/h)	1,000,000 times or more (switching frequency 18,000/h)
	Electrical (Resistive load)	500 VDC 10 A 10,000 times 500 VDC 1 A 30,000 times (Switching frequency 1-second ON - 9-second OFF at 85°C)	300 VDC 10 A 10,000 times (Switching frequency 1-second ON - 9-second OFF at 85°C)
Ambient temperature range		-40 to +85°C (with no icing or condensation)	-40 to +85°C (with no icing or condensation)
Terminal shape		PCB terminals	PCB terminals
Safety standards		UL, TUV	UL, TUV
Weight		Approx. 22 g	Approx. 22 g

[Fig. 8: G2RG-X specifications]

Circuit diagrams

The G2RG-X is capable of switching of 500 VDC / 10 A by using 2 poles in series. It is also capable of switching 300 VDC / 10 A even when used with a single pole. Note that the switching portion has polarity, so please pay attention to the directionality in the circuit.

●1-pole series wiring

●2-poles series wiring

Note: The contacts have polarity. Proceed with caution.
The diode and zener diode are for coil surge absorption. (The coil has no polarity.)

[Fig. 9: G2RG-X circuit diagram]

Rated 500 VDC, 10 A (2-pole series connection) G2RG-X, a compact PCB power relay with DC high voltage switching

Overseas standard certification

The G2RG-X has obtained UL/TUV overseas standard certification for the rating of 2-pole series connection in addition to the rating of 1-pole connection. The certified rating values of overseas standards are different from the performance values specified individually. For the latest product information, please refer to the datasheet on our website.

UL Recognized: (File No. E41643)

Model	Contact form	Coil ratings	Contact ratings	Number of test operations
G2RG-2A-X	2a, 1 pole series wiring	12, 24 VDC	10 A, 300 VDC (Resistive) 85°C	10,000
	2a, 2-poles series wiring		10 A, 500 VDC (Resistive) 85°C	10,000
			1 A, 500 VDC (Resistive) 85°C	30,000

EN/IEC, TÜV Certified Model (Approval/No. R50468711)

Model	Contact form	Coil ratings	Contact ratings	Number of test operations
G2RG-2A-X	2a, 1 pole series wiring	12, 24 VDC	10 A, 300 VDC (Resistive) 85°C	10,000
	2a, 2-poles series wiring		10 A, 500 VDC (Resistive) 85°C	10,000
			1 A, 500 VDC (Resistive) 85°C	30,000

[Fig. 10: Overseas standard certification obtained for G2RG-X relays]

Rated 500 VDC, 10 A (2-pole series connection) G2RG-X, a compact PCB power relay with DC high voltage switching

Reference data: Initial contact resistance

The initial contact resistance of the G2RG-X is 100 mΩ or less as rated performance. The graph below shows the product's actual performance value is less than 50 mΩ, achieving stable low contact resistance. The values listed here are reference values, not guaranteed values.

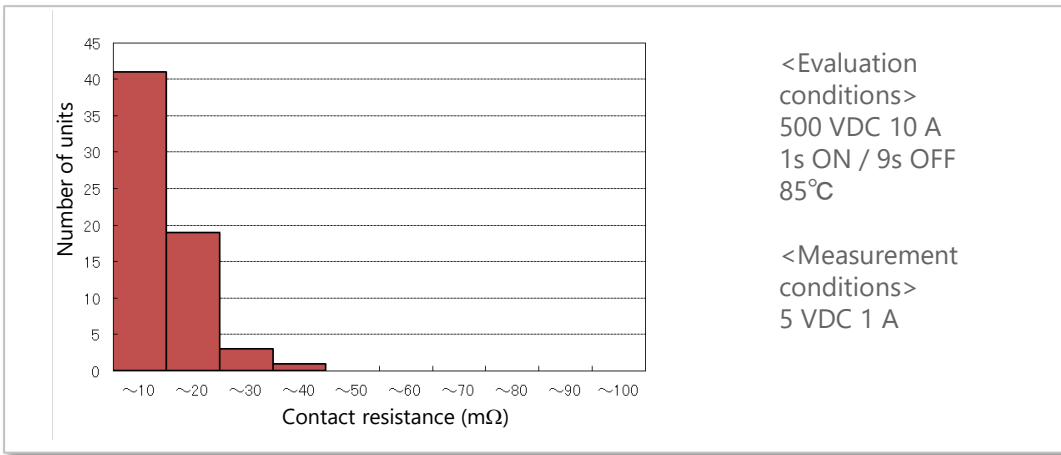

[Fig. 11: G2RG-X initial contact resistance (when 1 pole is connected)]

Reference data: Contact resistance after electrical durability testing

The G2RG-X maintains low contact resistance even after electrical durability evaluation. The graph below shows that the contact resistance increases by about 20% from the initial value, contributing to low heat generation throughout the product life cycle. The values listed here are reference values, not guaranteed values.

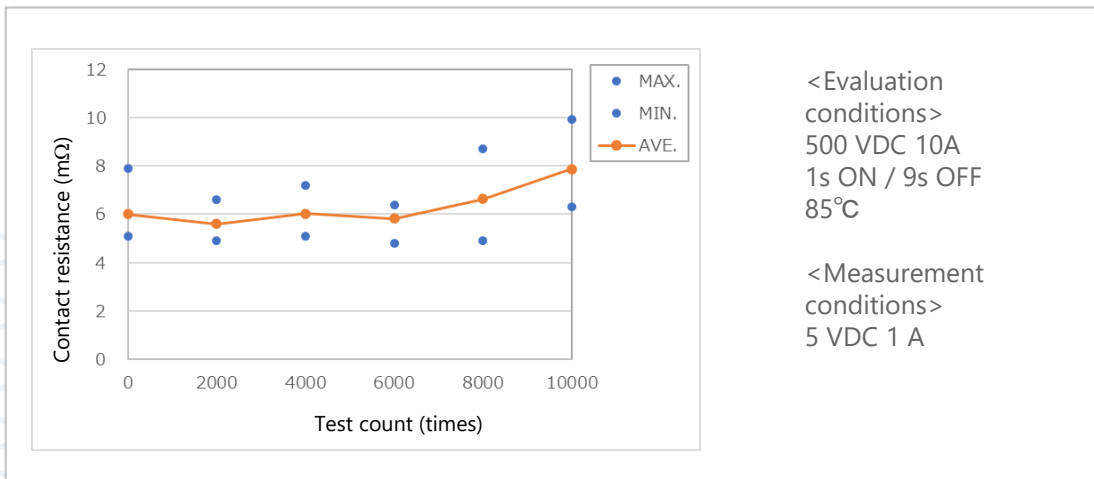

[Fig. 12: G2RG-X contact resistance values after electrical durability test]

Rated 500 VDC, 10 A (2-pole series connection) G2RG-X, a compact PCB power relay with DC high voltage switching

Reference data: Electrical durability G2RG-2A-X (2-poles series wiring)

In order to meet a wide range of customer load requests, we disclose durability curves. Please make use of this information when designing your products to consider whether or not to apply relays. However, these data are actual values, not guaranteed values.

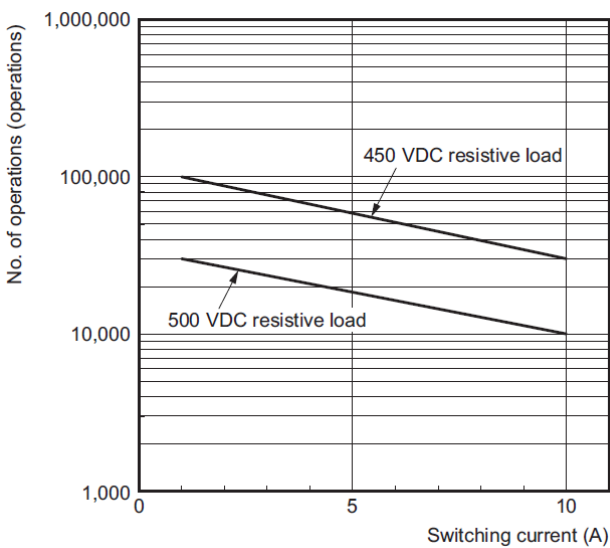

[Fig. 13: Electrical durability]

Usage explanation: Operating coil circuit

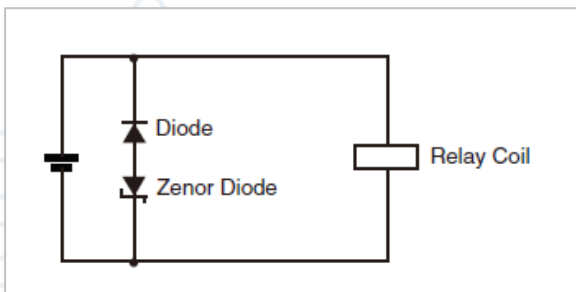

[Fig. 14: Diode / Zener diode connection]

Use diodes to absorb coil surges. Zener diodes must be used in conjunction with the G2RG-X to achieve its switching performance. The diode must be connected with the reverse polarity of the voltage applied to the coil.

- The recommended Zener voltage for Zener diodes is 3 times of the coil rated voltage.
- Dielectric withstanding voltage of the diode must be at least 10 times as large as the rated coil voltage value. The forward current of the diode must be the same as or larger than the coil current value.

Please check each region's Terms & Conditions by region website.

OMRON Corporation

Device & Module Solutions Company

Regional Contact

Americas

<https://components.omron.com/us-en/>

Asia-Pacific

<https://components.omron.com/sg-en/>

Korea

<https://components.omron.com/kr-en/>

Europe

<https://components.omron.com/eu-en/>

China

<https://components.omron.com.cn/>

Japan

<https://components.omron.com/jp-ja/>